

# A counterintuitive toy: the bird that never falls down

J Fort, J E Llebot, J Saurina and J J Suñol

*University of Girona, Catalonia, Spain*

**We describe a toy that has the shape of a bird. It has the intuitively astonishing property that, no matter how far away from the equilibrium position it is moved, it oscillates back to this position. We explain the behaviour of this physical system and use it to illustrate the concept of mechanical stability and the usefulness of making simple, idealized models for the description of complex systems.**

The toy depicted in figure 1 consists of two parts. One part has the shape of a bird; the other is just a support. The sharp end of the bird's beak can be placed in contact with the support (although the two parts are *not* stuck together). Figure 1(a) shows the equilibrium position. If the bird is moved from this position (figure 1(b))

and released, it turns out that it does not fall off the support, as might be expected intuitively. Instead, it oscillates around, and eventually returns to, the equilibrium position. It is astonishing that this happens even if the bird is initially in the vertical position (figure 1(c)). This is a remarkable physical system: why does the bird return to the equilibrium position instead of falling off the support?

## Why the bird does not fall off

Our bird is made of a translucent plastic material and, when observed against a lamp, it is seen that there is a mass inside the end of each wing. The reason for its behaviour is based on the following point (see figure 2): in the equilibrium position, the ends of the wings are at a height that is lower

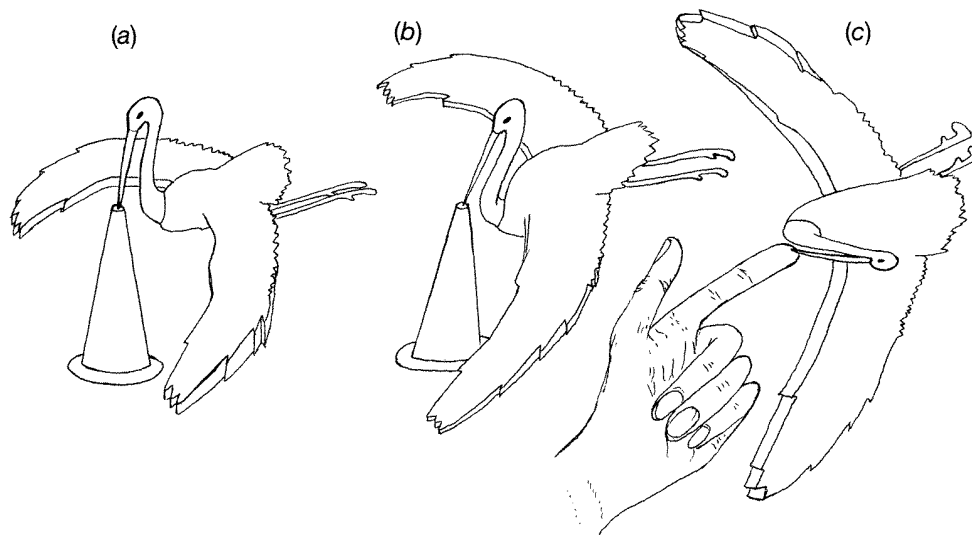

**Figure 1.** The bird that never falls down. In (a), the bird is at its equilibrium position. If moved from it, as in (b) and (c), and released, the bird does not fall off but oscillates back to its equilibrium position.

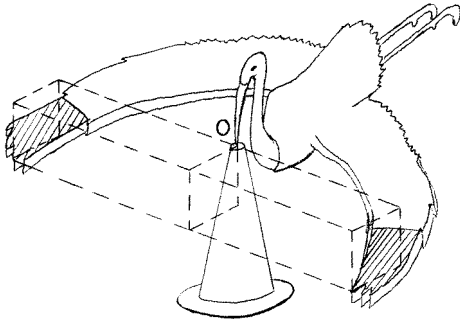
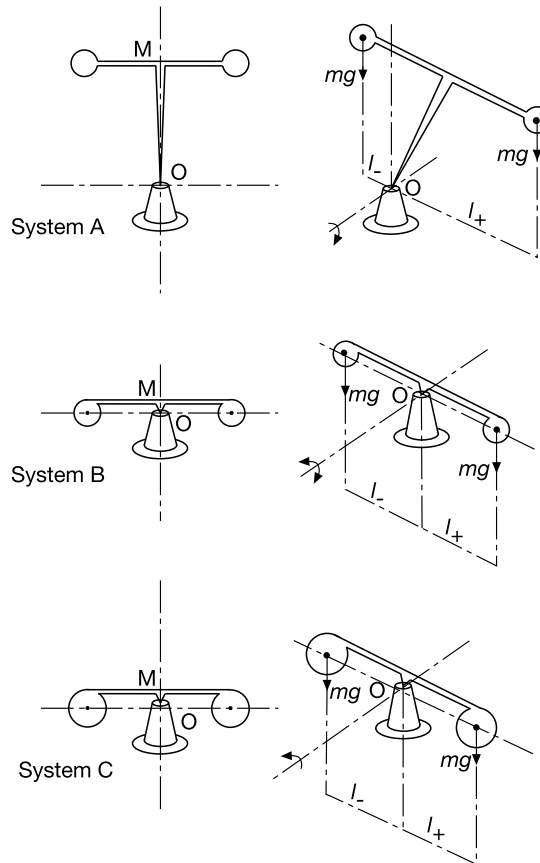

**Figure 2.** The ends of the bird's wings are at a lower height than the point of support (point O). This, together with the fact that the outer part of the wings contains two masses (shaded regions), is the reason for the stability of the bird.

than the end of the beak (point O in figure 2). We will now justify this explanation.

Consider the three simple systems depicted in figure 3. They all consist of two equal masses, joined by a light rod. At the middle point M, a second rod begins. Its sharp end (point O) is in contact with a support. Let us assume both rods to be of negligible mass. In the case of system A, in the equilibrium position the two masses are above point O. For system B the centres of the masses and point O are at the same height. Finally, in the case of system C the centres of the masses are below point O. For any one of the three systems, in the horizontal position the mass on the right in figure 3 exerts a torque  $\tau^+ = mgL/2$ , which tends to rotate the system in the clockwise direction, but it is compensated since the mass on the left exerts a torque  $\tau^- = mgL/2$  in the counterclockwise direction. Here  $m$  is the value of each mass,  $g$  the constant of gravitational acceleration and  $L$  the length of the rod that connects the two masses. Now assume that the systems are removed from their equilibrium states. The right-hand side of figure 3 defines the distances  $l_+$  and  $l_-$ . For system A we have  $l_+ > l_-$  and therefore  $\tau_+ - \tau_- = mg(l_+ - l_-) > 0$ , so that the system rotates away from the equilibrium position. Thus the equilibrium is unstable [1]. For system B we have  $l_+ = l_-$  and therefore  $\tau_+ - \tau_- = mg(l_+ - l_-) = 0$ . Finally, for system C  $\tau_+ - \tau_- = mg(l_+ - l_-) < 0$ , so that the system rotates towards the equilibrium position, which is therefore stable.

We can now explain why the bird does not fall off. The bird is a complex physical system that can

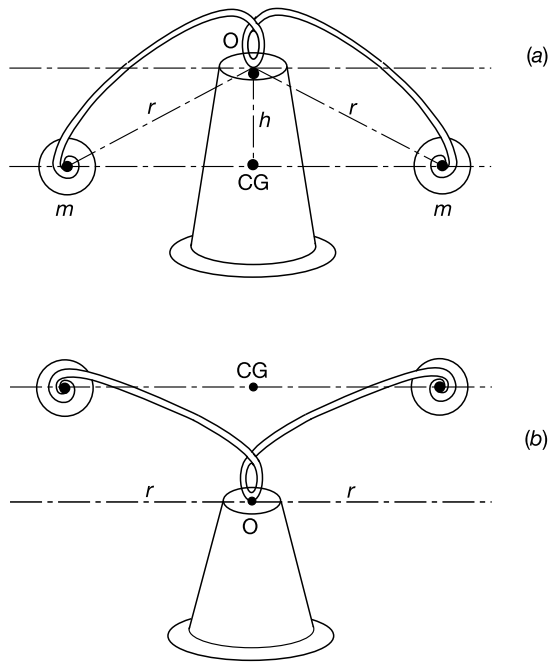

**Figure 3.** On the left we present the front view of three simple systems at their equilibrium positions. On the right, the same systems are depicted, in a three-dimensional perspective, in a nonequilibrium position.

be approximated to system C in figure 3: in both cases, in the equilibrium position the masses (the outer part of the wings in the case of the bird) are below the point of support (the end of the bird's beak).

### Experimental verification of the proposed explanation

We took a piece of wire and modelled it as shown in figure 4(a). In each end of the wire, we put a drawing pin. This system is stable: if put on one's finger, it immediately begins to oscillate. In equilibrium, the drawing pins are below the point O of support. Thus this is an experimental realization of system C in figure 3. However, if the wire is modelled as in figure 4(b), it inevitably



**Figure 4.** This simple system (a thin, light wire with a drawing pin at each end) provides a compelling experimental check of the reason why the bird in figure 1 does not fall off (CG stands for the centre of gravity).

falls down to the ground. This case corresponds to system A in figure 3.

Let us assume that our bird can be approximated to three masses and rods (figure 5(a)). Consider oscillations about the symmetry axis OR. The weight  $Mg$  crosses this axis and therefore makes no torque. An observer located on axis OR sees what is depicted in figure 5(b) if s/he is observing the bird (if s/he were observing the simpler system formed by the three masses and rods, s/he would see what is depicted in figure 5(c)). The resulting torque is

$$\begin{aligned} \tau &= mgl_+ - mgl_- \\ &= mg(a - h \sin \theta) - mg(a + h \sin \theta) \\ &= -2mgh \sin \theta \end{aligned} \tag{1}$$

where the necessary quantities have been defined in figure 5(c).

The moment of inertia about the considered axis is

$$I = 2mr^2. \tag{2}$$

For small oscillations we have  $\sin \theta \approx \theta$ . Since

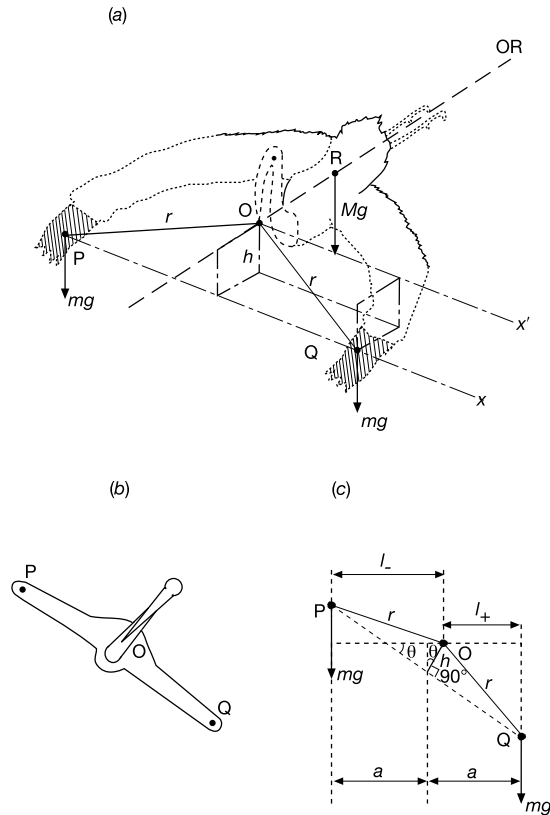

**Figure 5.** The toy bird can be roughly approximated to the simpler system shown in (a). Broken lines correspond to the physical system (the bird); full lines correspond to the simpler, model system considered (three masses located at points P, Q and R, and three light rods OP, OQ and OR). OR is the symmetry axis of the bird and of our simpler, model system. If a wing of the bird is raised and then released, the bird oscillates around the OR axis until it reaches equilibrium.

$$\tau = I d^2\theta/dt^2,$$

$$\frac{d^2\theta}{dt^2} = -\frac{gh}{r^2}\theta. \tag{3}$$

The period of this oscillation is

$$T = 2\pi \frac{r}{\sqrt{gh}} \tag{4}$$

which is independent of  $m$ .

For the bird (figure 5(a)) we measured  $r = 76$  mm and  $h = 14$  mm. Thus equation (4) predicts  $T_{\text{theory}} = 1.3$  s. We made use of a chronometer to record the time that it takes the bird to make 30 swings. Dividing by 30 we

found  $T_{\text{exp}} = 1.6$  s. The relative difference with respect to the theoretical value is 23%. This is an important difference and cannot be entirely attributed to measurement errors.

We can solve this problem by going back to the simple experiment proposed at the beginning of this section. We modelled a wire such that the values of  $r$  and  $d$  in figure 4(a) are the same as those for the bird. After repeating the measurements for the system in figure 4(a) instead of the bird, we obtained  $T_{\text{exp}} = 1.4$  s. In this case the absolute difference with respect to the theoretical value is only 0.1 s, which can be due to measurement errors. Thus equation (4) is more accurate for the system in figure 4(a) than for the

toy bird due simply to the fact that in the latter case one should also take into account the mass of the wings and other parts of the body, not just the masses that are hidden inside the outer part of the wings. However, the simple system depicted in figure 4(a) has allowed us to check experimentally the explanation for the bird's behaviour.

*Received 28 July 1997, in final form 26 September 1997*  
*PII: S0031-9120(98)86394-6*

## Reference

- [1] See, e.g., Tipler P A 1991 *Physics for Scientists and Engineers* vol I (New York: Worth) ch 9